

Polymer PTC Resettable Fuse: KMC Series

SMD Type



■ Features

1. RoHS & Halogen-Free (HF) compliant
2. EIA size: 0603, 0805, 1206, 1210, 1812, 2018
3. Hold current ratings from 0.02~5A
4. Voltage ratings from 6V computer and electronic applications to 60V
5. Small footprint
6. Fast time to trip
7. Operating & storage temperature range: -40~+85°C
8. Agency approval: UL / cUL / TUV

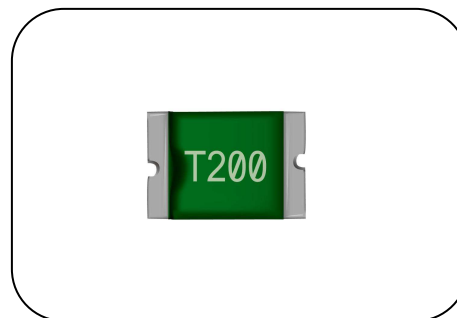

■ Recommended Applications

1. USB, HDMI, IEEE 1394 interface
2. PC, Motherboard, NB, Tablet
3. Mobile phone
4. Digital cameras
5. Telecommunication
6. Consumer device

■ Part Number Code

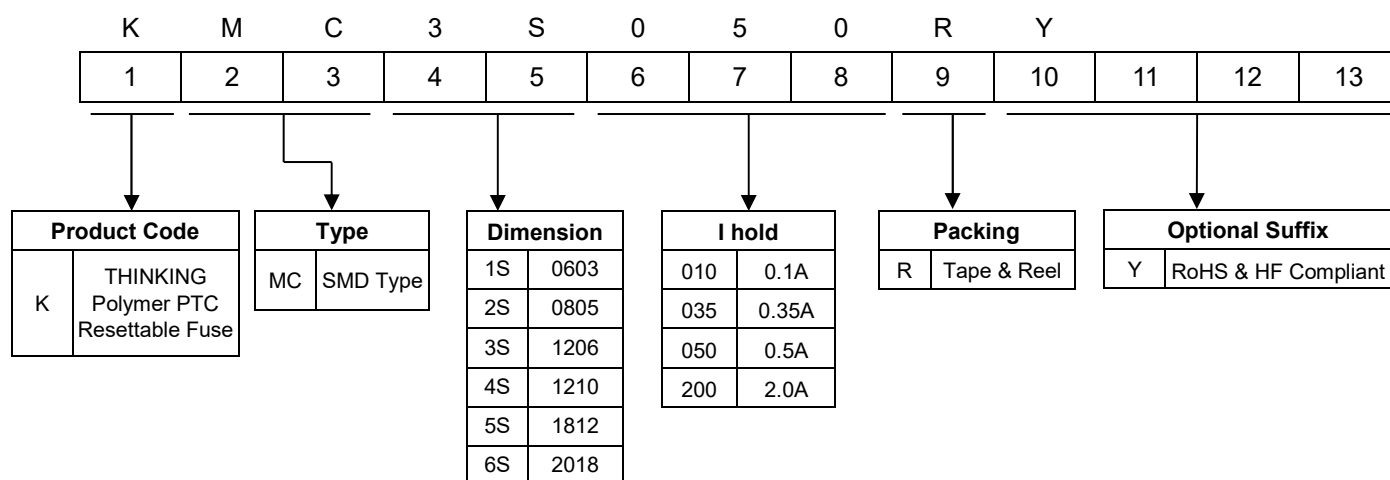

Polymer PTC Resettable Fuse: KMC Series

SMD Type



■ Structure & Dimensions

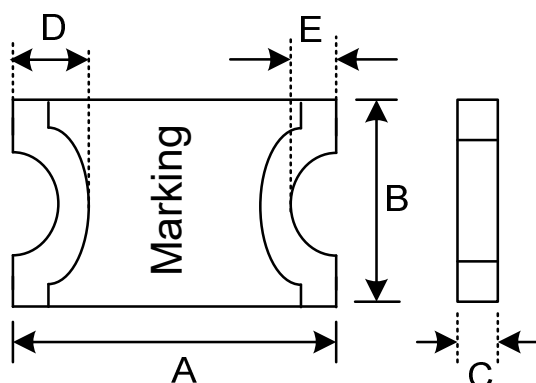

(Unit: mm)

Part No.	A		B		C		D		E	
	(Min.)	(Max.)	(Min.)	(Max.)	(Min.)	(Max.)	(Min.)	(Max.)	(Min.)	(Max.)
KMC1S010	1.40	1.80	0.60	1.00	0.30	0.55	0.15	0.50	--	0.40
KMC1S020					0.30	0.55				
KMC1S025					0.30	0.55				
KMC1S035					0.50	0.70				
KMC2S002	2.00	2.20	1.20	1.50	0.4	0.85	0.15	0.55	0.05	0.45
KMC2S005					0.4	0.85				
KMC2S006					0.55	0.85				
KMC2S008					0.55	0.85				
KMC2S010					0.40	0.85				
KMC2S010-24					0.40	0.85				
KMC2S012					0.4	0.85				
KMC2S020					0.40	0.85				
KMC2S035					0.30	0.75				
KMC2S050					0.30	0.85				
KMC2S075					0.50	0.85				
KMC2S110	0.50	0.90								

Polymer PTC Resettable Fuse: KMC Series

SMD Type



■ Structure & Dimensions

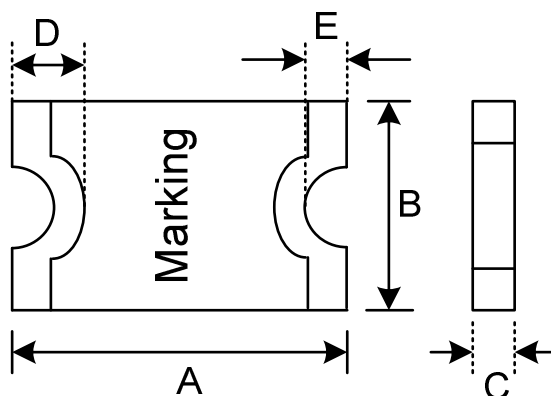

(Unit: mm)

Part No.	A		B		C		D		E	
	(Min.)	(Max.)	(Min.)	(Max.)	(Min.)	(Max.)	(Min.)	(Max.)	(Min.)	(Max.)
KMC3S005	3.00	3.50	1.50	1.80	0.50	0.90	0.125	0.75	0.08	0.45
KMC3S010					0.50	0.90				
KMC3S012					0.35	0.75				
KMC3S016					0.28	0.68				
KMC3S020					0.28	0.68				
KMC3S025					0.28	0.68				
KMC3S035					0.28	0.68				
KMC3S050					0.28	0.68				
KMC3S050-15					0.28	1.06				
KMC3S075					0.28	0.75				
KMC3S100					0.40	0.88				
KMC3S110					0.40	0.88				
KMC3S110-16					0.80	1.40				
KMC3S150					0.55	1.35				
KMC3S200					0.80	1.35				

Polymer PTC Resettable Fuse: KMC Series

SMD Type



■ Structure & Dimensions

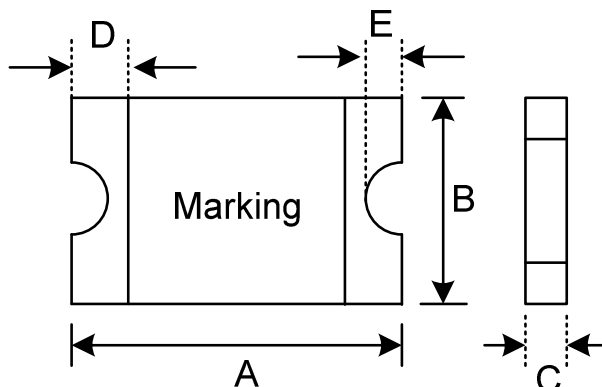

(Unit: mm)

Part No.	A		B		C		D		E	
	(Min.)	(Max.)	(Min.)	(Max.)	(Min.)	(Max.)	(Min.)	(Max.)	(Min.)	(Max.)
KMC4S005	3	3.43	2.35	2.8	0.55	1.15	0.125	0.75	0.08	0.5
KMC4S010					0.55	1.15				
KMC4S020					0.28	0.68				
KMC4S035					0.28	0.68				
KMC4S050					0.28	0.68				
KMC4S075					0.28	0.68				
KMC4S110					0.28	0.68				
KMC4S150					0.45	1.00				
KMC4S175					0.55	1.20				

Polymer PTC Resettable Fuse: KMC Series

SMD Type



■ Structure & Dimensions

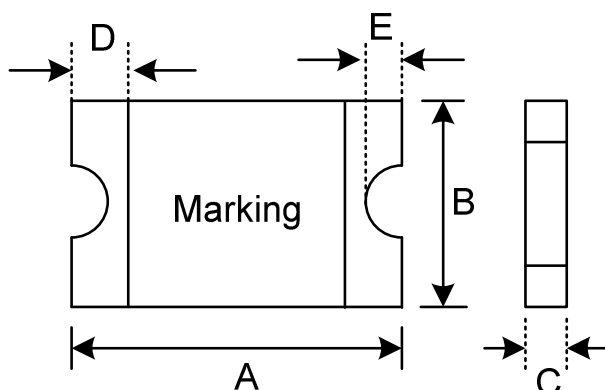

(Unit: mm)

Part No.	A		B		C		D		E	
	(Min.)	(Max.)	(Min.)	(Max.)	(Min.)	(Max.)	(Min.)	(Max.)	(Min.)	(Max.)
KMC5S010	4.37	4.73	3.07	3.41	0.50	0.90	0.20	1.2	0.15	0.65
KMC5S014					0.50	0.90				
KMC5S020					0.50	0.90				
KMC5S035					0.28	0.68				
KMC5S050					0.28	0.68				
KMC5S075					0.28	0.68				
KMC5S075-24					0.60	1.20				
KMC5S075-33					0.60	1.20				
KMC5S110					0.28	0.68				
KMC5S110-16					0.60	1.00				
KMC5S110-24					0.60	1.00				
KMC5S110-33					0.80	1.60				
KMC5S125					0.28	0.68				
KMC5S125-16					0.30	1.25				
KMC5S150					0.28	0.68				
KMC5S150-12					0.60	1.00				
KMC5S150-24					0.70	1.50				
KMC5S160					0.28	0.68				
KMC5S200					0.35	0.85				
KMC5S200-16					0.80	1.60				
KMC5S260	0.35	0.90								
KMC5S260-16	0.35	2.00								
KMC5S300	0.60	1.20								

Polymer PTC Resettable Fuse: KMC Series

SMD Type



■ Structure & Dimensions

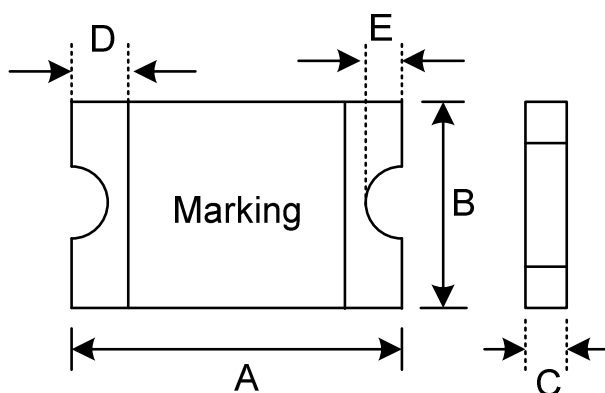

(Unit: mm)

Part No.	A		B		C		D		E	
	(Min.)	(Max.)	(Min.)	(Max.)	(Min.)	(Max.)	(Min.)	(Max.)	(Min.)	(Max.)
KMC6S030	4.72	5.44	3.7	4.43	0.75	1.25	0.3	1.5	0.25	0.65
KMC6S050					1.20	2.00				
KMC6S075					1.20	2.00				
KMC6S100					0.50	0.85				
KMC6S100-33					0.75	1.25				
KMC6S150					0.75	1.55				
KMC6S150-33					0.80	1.60				
KMC6S200					0.50	0.75				
KMC6S260-24					0.70	1.50				
KMC6S300					0.80	1.60				
KMC6S500					0.80	1.60				

Polymer PTC Resettable Fuse: KMC Series

SMD Type



Electrical Characteristics at 23°C

Part No.	Marking	Vmax.	I _{max} .	I _{hold}	I _{trip}	Pd (Max.)	Maximum Time to Trip		Resistance		Safety Approvals	
		(V _{dc})	(A)	(A)	(A)	(W)	Current	Time	Initial Ri	Post Trip R1	UL/cUL	TUV
							(A)	(Sec.)	Min. (Ω)	Max. (Ω)		
KMC1S010	1	15	40	0.10	0.30	0.50	0.50	1.00	0.900	6.000	√	√
KMC1S020	2	9	40	0.20	0.50	0.50	1.00	0.60	0.550	3.500	√	√
KMC1S025	5	9	40	0.25	0.55	0.50	8.00	0.08	0.500	3.000	√	√
KMC1S035	7	6	40	0.35	0.75	0.50	8.00	0.10	0.200	1.000	√	√
KMC2S002	A2	60	40	0.02	0.06	0.5	0.1	1.50	8.00	85.00	√	-
KMC2S005	A5	60	40	0.05	0.15	0.5	0.5	1.50	1.50	50.00	√	-
KMC2S006	A6	6	40	0.06	0.25	0.5	0.3	1.00	0.50	12.00	√	-
KMC2S008	A8	6	40	0.08	0.30	0.5	0.3	5.00	0.50	8.00	√	-
KMC2S010	D	15	100	0.10	0.30	0.50	0.50	1.50	1.000	6.000	√	√
KMC2S010-24	D	24	100	0.10	0.30	0.50	0.50	1.50	1.000	6.000	√	√
KMC2S012	A9	30	100	0.12	0.30	1	0.5	1.50	1.00	6.00	√	-
KMC2S020	L	9	100	0.20	0.50	0.50	8.00	0.02	0.650	3.500	√	√
KMC2S035	T	6	100	0.35	0.75	0.50	8.00	0.10	0.250	1.200	√	√
KMC2S050	O	6	100	0.50	1.00	0.50	8.00	0.10	0.150	0.850	√	√
KMC2S075	X	6	100	0.75	1.50	0.50	8.00	0.20	0.090	0.350	√	√
KMC2S110	V	6	40	1.10	2.00	0.60	8.00	0.30	0.060	0.210	√	-
KMC3S005	TH	60	100	0.05	0.15	0.40	0.25	1.50	3.600	50.000	√	√
KMC3S010	TY	60	100	0.10	0.25	0.40	0.50	1.00	1.600	15.000	√	√
KMC3S012	TJ	30	100	0.125	0.29	0.50	1.00	0.20	1.400	6.000	√	-
KMC3S016	TK	30	100	0.16	0.37	0.50	1.00	0.30	1.100	4.500	√	√
KMC3S020	TL	24	100	0.20	0.42	0.60	8.00	0.10	0.650	2.600	√	
KMC3S025	TN	16	100	0.25	0.50	0.60	8.00	0.08	0.550	2.300	√	√
KMC3S035	TP	16	100	0.35	0.75	0.60	8.00	0.10	0.300	1.200	√	√
KMC3S050	TQ	8	100	0.50	1.00	0.60	8.00	0.10	0.150	0.700	√	√
KMC3S050-15	TQ1	15	100	0.50	1.00	0.90	8.00	0.10	0.150	0.700	√	√
KMC3S075	TR	8	100	0.75	1.50	0.60	8.00	0.10	0.100	0.290	√	√
KMC3S100	TS	6	100	1.00	1.80	0.80	8.00	0.30	0.065	0.210	√	√
KMC3S110	TU	8	100	1.10	2.20	0.80	8.00	0.10	0.070	0.200	√	√
KMC3S110-16	TU1	16	100	1.10	2.20	0.80	8.00	0.10	0.06	0.21	√	√
KMC3S150	TV	8	100	1.50	3.00	0.80	8.00	0.30	0.040	0.120	√	√
KMC3S200	TX	6	100	2.00	3.50	1.00	8.00	1.50	0.020	0.080	√	√

Note : UL&cUL File No: E138827

TUV File No: R50143386 & R50279312

Polymer PTC Resettable Fuse: KMC Series

SMD Type



■ Electrical Characteristics at 23°C

Part No.	Marking	V _{max.}	I _{max.}	I _{hold}	I _{trip}	P _d (Max.)	Maximum Time to Trip		Resistance		Safety Approvals	
		(V _{dc})	(A)	(A)	(A)	(W)	Current	Time	Initial Ri	Post Trip R1	UL/cUL	TUV
							(A)	(Sec.)	Min. (Ω)	Max.(Ω)		
KMC4S005	Ta	30	10	0.05	0.15	0.6	0.25	1.50	3.60	50.00	√	√
KMC4S010	Tb	30	10	0.10	0.30	0.6	0.5	1.50	1.60	15.00	√	√
KMC4S020	Td	30	10	0.20	0.40	0.6	8.0	0.02	0.80	5.00	√	√
KMC4S035	Tf	6	100	0.35	0.70	0.6	8.0	0.20	0.32	1.30	√	√
KMC4S050	Tg	16	100	0.50	1.00	0.6	8.0	0.10	0.25	0.90	√	√
KMC4S075	Th	8	100	0.75	1.50	0.6	8.0	0.10	0.11	0.40	√	√
KMC4S110	Tm	6	100	1.10	2.20	0.6	8.0	0.30	0.06	0.21	√	√
KMC4S150	Tn	6	100	1.50	3.00	0.8	8.0	0.50	0.04	0.11	√	√
KMC4S175	Tr	6	40	1.75	3.50	0.8	8.0	0.80	0.02	0.08	√	√

Note : UL&cUL File No: E138827

TUV File No: R50143386

■ Electrical Characteristics at 23°C

Part No.	Marking	V _{max.}	I _{max.}	I _{hold}	I _{trip}	P _d (Max.)	Maximum Time to Trip		Resistance		Safety Approvals	
		(V _{dc})	(A)	(A)	(A)	(W)	Current	Time	Initial Ri	Post Trip R1	UL/cUL	TUV
							(A)	(Sec.)	Min. (Ω)	Max.(Ω)		
KMC5S010	T 010	30	100	0.10	0.30	0.80	0.50	1.50	1.600	15.000	√	√
KMC5S014	T 014	60	10	0.14	0.34	0.80	1.50	0.15	1.500	6.000	√	√
KMC5S020	T 020	30	100	0.20	0.40	0.80	8.00	0.02	0.800	5.000	√	√
KMC5S035	T 035	16	100	0.35	0.70	0.80	8.00	0.10	0.320	1.500	√	√
KMC5S050	T 050	16	100	0.50	1.00	0.80	8.00	0.15	0.150	1.000	√	√
KMC5S075	T 075	16	100	0.75	1.50	0.80	8.00	0.20	0.110	0.450	√	√
KMC5S075-24	T ⁰⁷⁵ ₂₄	24	100	0.75	1.50	1.0	8.00	0.20	0.110	0.400	√	√
KMC5S075-33	T ⁰⁷⁵ ₃₃	33	20	0.75	1.50	1.2	8.00	0.20	0.110	0.400	√	√
KMC5S110	T 110	8	100	1.10	2.20	0.80	8.00	0.30	0.040	0.210	√	√
KMC5S110-16	T ¹¹⁰ ₁₆	16	100	1.10	2.20	1.0	8.00	0.50	0.060	0.180	√	√

Polymer PTC Resettable Fuse: KMC Series

SMD Type



KMC5S110-24	T ₂₄ ¹¹⁰	24	20	1.10	2.20	1.2	8.00	0.50	0.060	0.200	√	√
KMC5S110-33	T ₃₃ ¹¹⁰	33	20	1.10	2.20	1.2	8.00	0.50	0.060	0.200	√	√
KMC5S125	T 125	6	100	1.25	2.50	0.80	8.00	0.40	0.050	0.140	√	√
KMC5S125-16	T ₁₆ ¹²⁵	16	100	1.25	2.50	1.0	8.00	0.40	0.050	0.140	√	√
KMC5S150	T 150	8	100	1.50	3.00	0.90	8.00	0.30	0.040	0.110	√	√
KMC5S150-12	T ₁₂ ¹⁵⁰	12	100	1.50	3.00	1.0	8.00	0.50	0.040	0.110	√	√
KMC5S150-24	T ₂₄ ¹⁵⁰	24	20	1.50	3.00	1.2	8.00	1.50	0.040	0.120	√	√
KMC5S160	T 160	8	100	1.60	3.20	0.80	8.00	1.00	0.030	0.100	√	√
KMC5S200	T 200	8	100	2.00	3.50	1.20	8.00	2.00	0.020	0.060	√	√
KMC5S200-16	T 200	16	100	2.00	3.50	1.20	8.00	2.00	0.020	0.060	√	-
KMC5S260	T 260	8	100	2.60	5.00	1.20	8.00	2.50	0.015	0.047	√	√
KMC5S260-16	T 260	16	100	2.60	5.00	1.5	8.00	5.0	0.015	0.050	√	-
KMC5S300	T 300	6	100	3.00	5.00	1.20	8.00	4.00	0.012	0.040	√	√

Note : UL&cUL File No: E138827
TUV File No: R50143386

Polymer PTC Resettable Fuse: KMC Series

SMD Type



■ Electrical Characteristics at 23°C

Part No.	Marking	V _{max.}	I _{max.}	I _{hold}	I _{trip}	Pd (Max.)	Maximum Time to Trip		Resistance		Safety Approvals	
							Current (A)	Time (Sec.)	Initial Ri	Post Trip R1	UL/cUL	TUV
		(V _{dc})	(A)	(A)	(A)	(W)			Min. (Ω)	Max.(Ω)		
KMC6S030	K030	60	20	0.30	0.60	1.40	1.50	3.00	0.500	2.300	-	√
KMC6S050	K050	60	20	0.55	1.10	1.40	2.50	5.00	0.200	1.000	-	√
KMC6S075	K075	60	20	0.75	1.50	1.40	8.00	0.50	0.130	0.900	-	√
KMC6S100	K100	15	40	1.10	2.20	1.40	8.00	0.50	0.100	0.400	-	√
KMC6S100-33	K ¹⁰⁰ ₃₃	33	40	1.10	2.20	1.40	8.00	0.50	0.100	0.400	-	√
KMC6S150	K150	15	40	1.50	3.00	1.40	8.00	1.00	0.070	0.180	-	√
KMC6S150-33	K ¹⁵⁰ ₃₃	33	40	1.50	3.00	2.00	8.00	1.00	0.070	0.180	-	√
KMC6S200	K200	6	40	2.00	4.20	1.40	8.00	3.00	0.048	0.100	-	√
KMC6S260-24	K ²⁶⁰ ₂₄	24	40	2.60	5.20	1.60	8.00	5.00	0.004	0.065	-	√
KMC6S300	K300	16	40	3.00	5.00	1.60	8.00	10.00	0.015	0.048	-	√
KMC6S500	K500	6	100	5.00	10.00	2.00	25.00	2.00	0.005	0.025	-	√

Note :TUV File No: R50606427

Polymer PTC Resettable Fuse: KMC Series SMD Type



Typical Time to Trip Curve at 23°C

KMC1S: 0603 Series

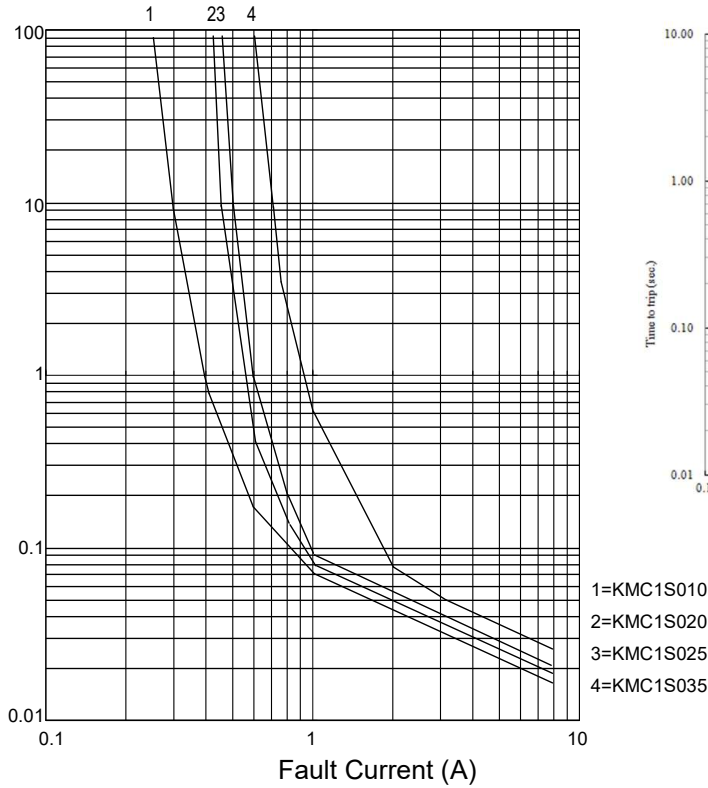

KMC2S: 0805 Series

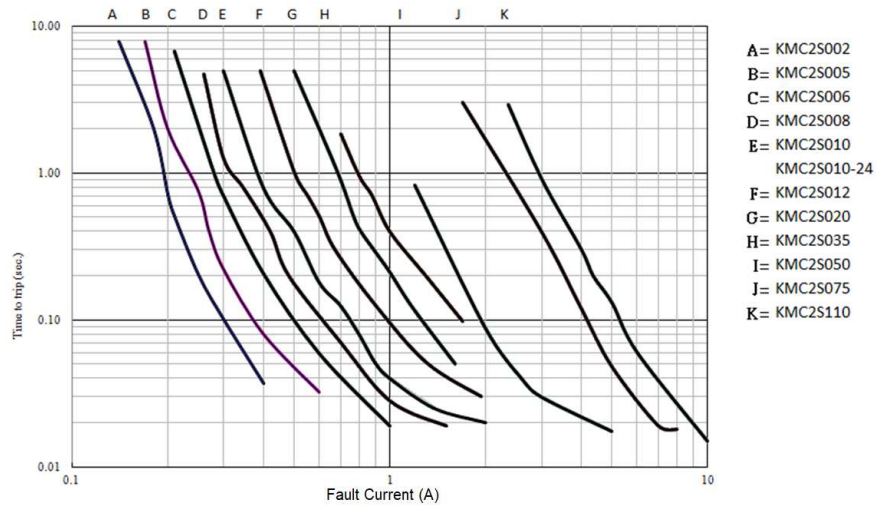

KMC3S: 1206 Series

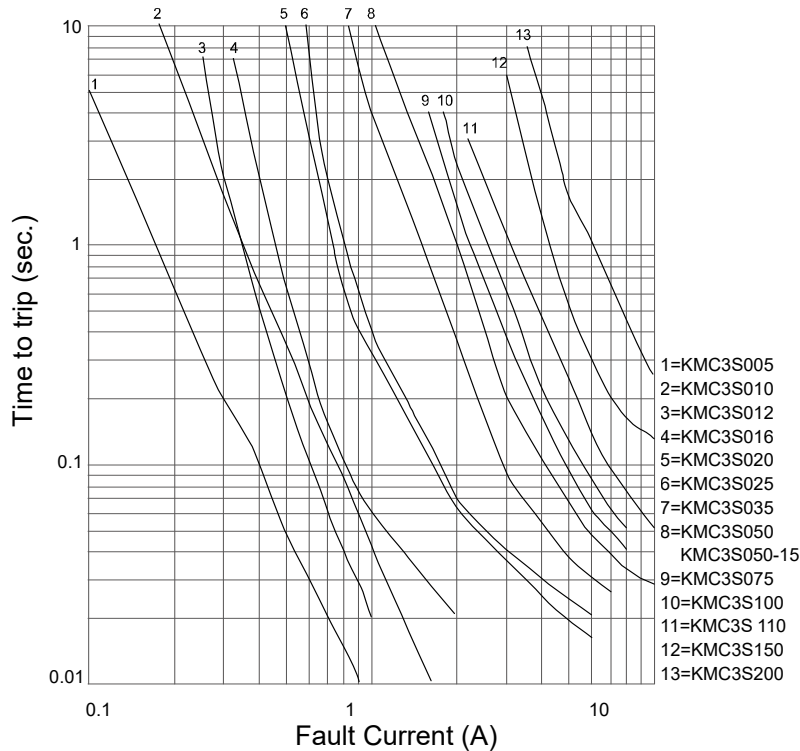

Polymer PTC Resettable Fuse: KMC Series SMD Type



■ Typical Time to Trip Curve at 23°C

KMC4S: 1210 Series

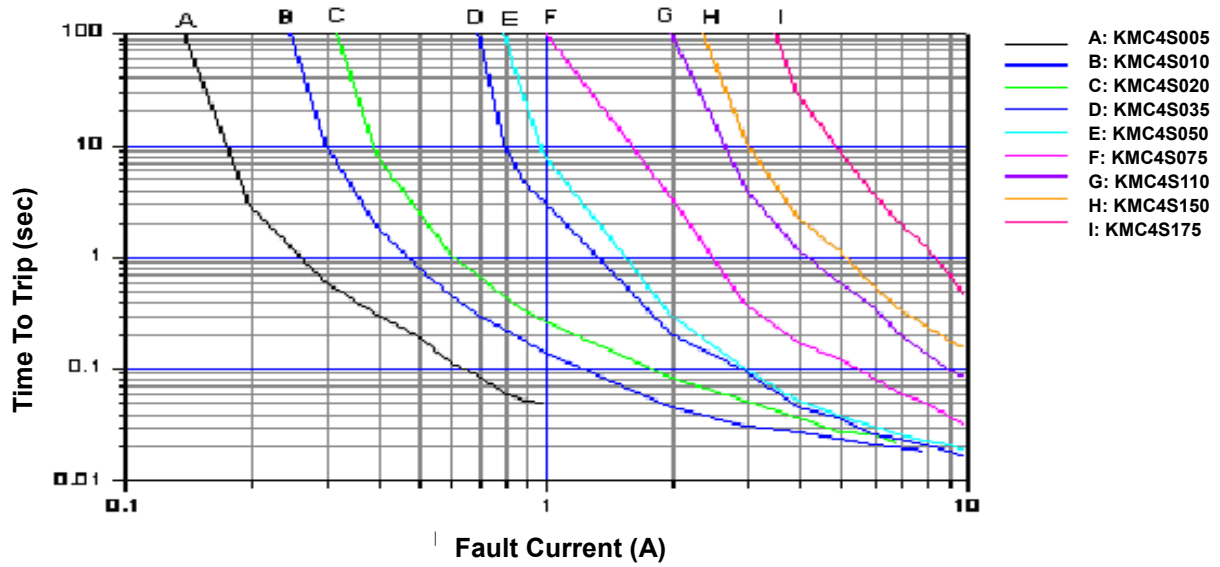

KMC5S: 1812 Series

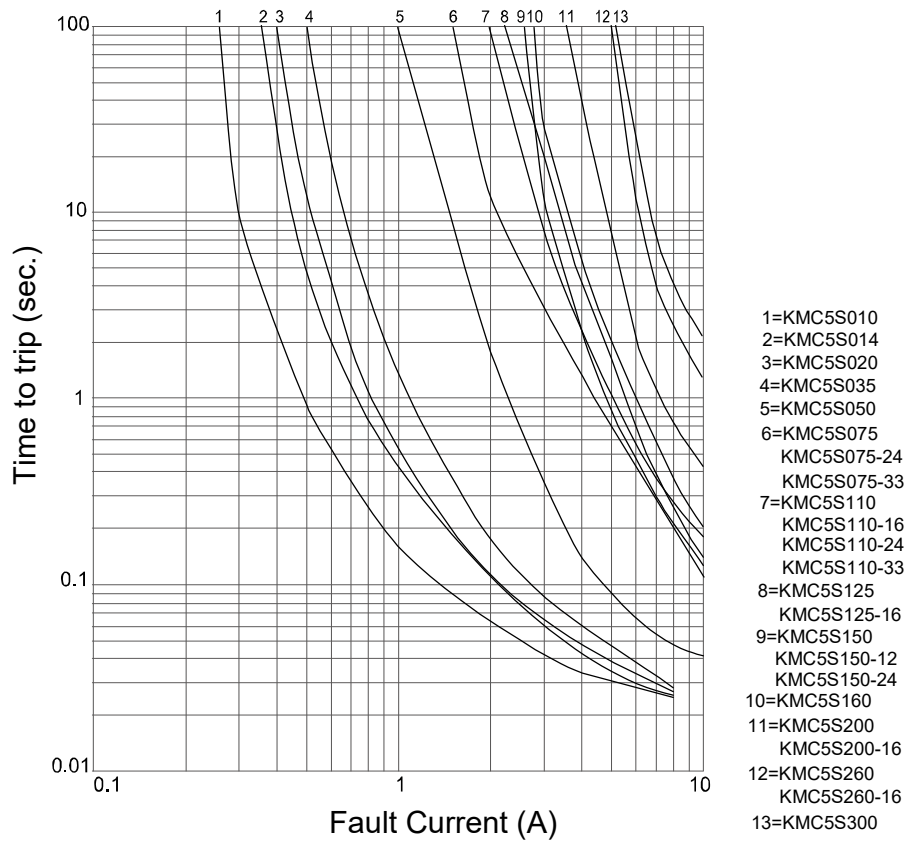

Polymer PTC Resettable Fuse: KMC Series SMD Type



■ Typical Time to Trip Curve at 23°C

KMC6S: 2018 Series

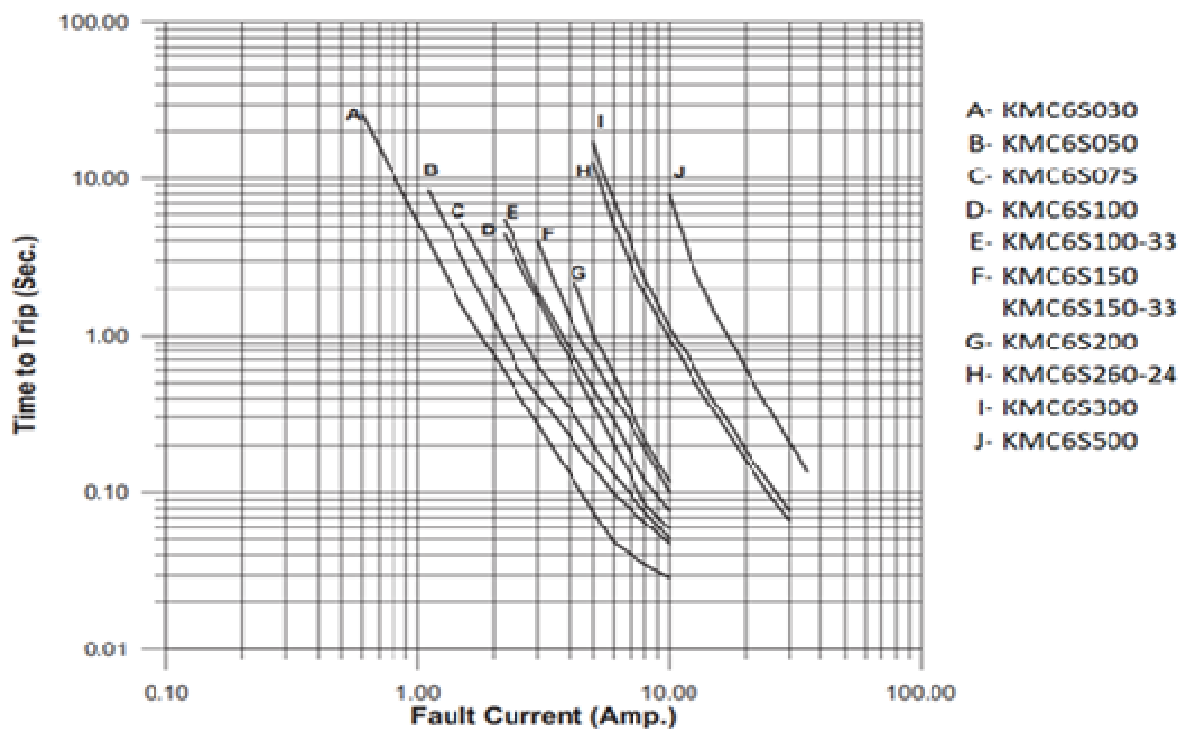



■ KMC1S (0603) Series Ihold & Itrip Thermal Derating Curve

Derating Curve for KMC1S (0603) Series

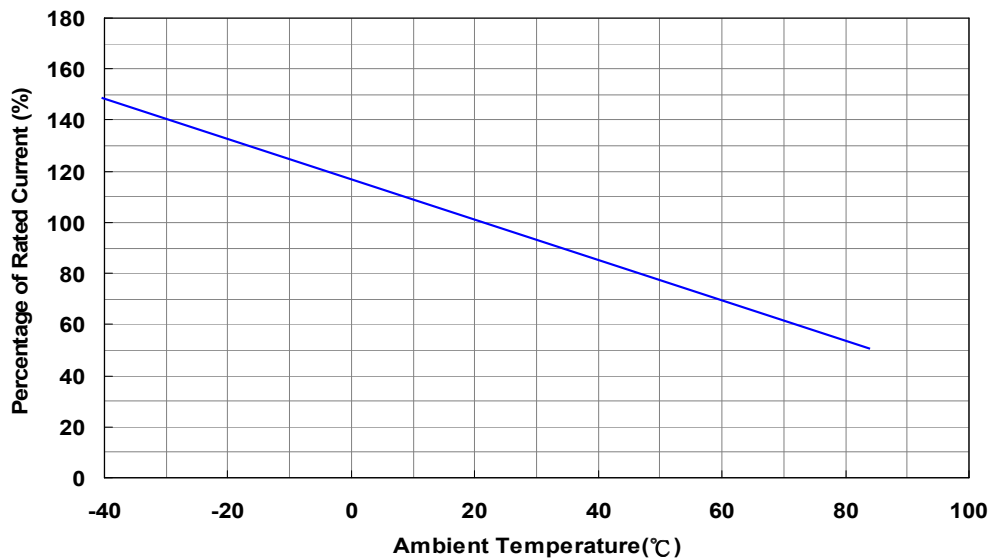

KMC1S (0603) Series Ihold Thermal Derating Chart

(Unit: A)

Part No.	Ambient Temperature								
	-40°C	-20°C	0°C	23°C	40°C	50°C	60°C	70°C	85°C
KMC1S010	0.13	0.12	0.11	0.10	0.08	0.07	0.06	0.05	0.03
KMC1S020	0.27	0.25	0.23	0.20	0.17	0.14	0.12	0.10	0.07
KMC1S025	0.32	0.29	0.27	0.25	0.21	0.18	0.16	0.14	0.10
KMC1S035	0.47	0.41	0.38	0.35	0.29	0.26	0.24	0.20	0.14

■ KMC2S (0805) Series Ihold & Itrip Thermal Derating Curve

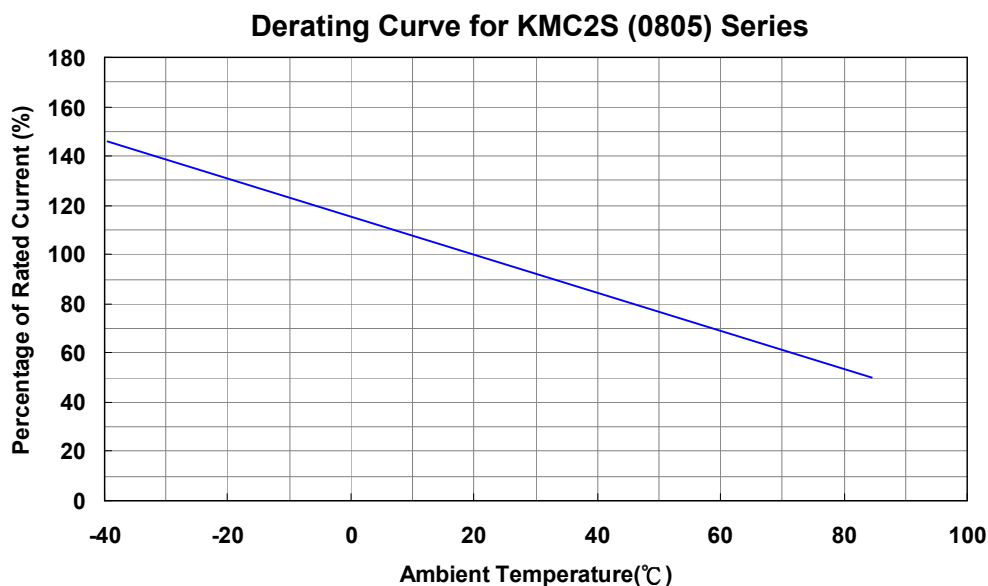

KMC2S (0805) Series Ihold Thermal Derating Chart

(Unit: A)

Part No.	Ambient Temperature								
	-40°C	-20°C	0°C	23°C	40°C	50°C	60°C	70°C	85°C
KMC2S002	0.030	0.027	0.023	0.020	0.017	0.015	0.013	0.011	0.007
KMC2S005	0.075	0.066	0.057	0.050	0.043	0.038	0.033	0.028	0.019
KMC2S006	0.085	0.080	0.065	0.060	0.050	0.045	0.040	0.034	0.023
KMC2S008	0.12	0.10	0.09	0.08	0.07	0.06	0.05	0.04	0.03
KMC2S010	0.14	0.12	0.11	0.10	0.08	0.07	0.06	0.05	0.03
KMC2S010-24	0.14	0.12	0.11	0.10	0.08	0.07	0.06	0.05	0.03
KMC2S012	0.16	0.15	0.13	0.12	0.10	0.09	0.08	0.07	0.05
KMC2S020	0.28	0.25	0.23	0.20	0.17	0.14	0.12	0.10	0.07
KMC2S035	0.47	0.44	0.39	0.35	0.30	0.27	0.24	0.20	0.14
KMC2S050	0.68	0.62	0.55	0.50	0.40	0.37	0.33	0.29	0.23
KMC2S075	1.00	0.90	0.79	0.75	0.63	0.57	0.53	0.41	0.34
KMC2S110	1.55	1.32	1.26	1.10	0.93	0.85	0.77	0.67	0.55

■ KMC3S (1206) Series Ihold & Itrip Thermal Derating Curve

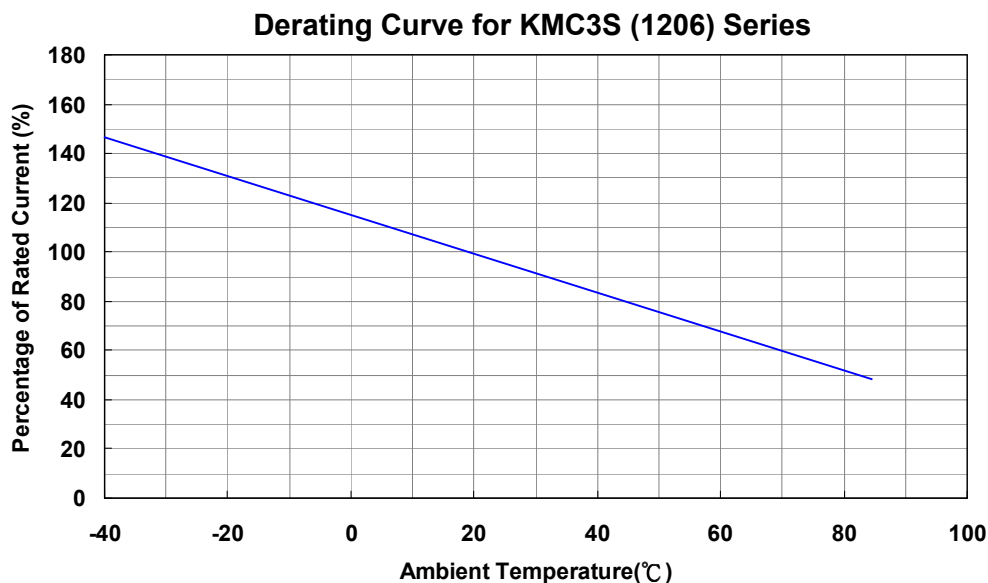

■ KMC3S (1206) Series Ihold Thermal Derating Chart

(Unit: A)

Part no	Ambient Temperature								
	-40°C	-20°C	0°C	23°C	40°C	50°C	60°C	70°C	85°C
KMC3S005	0.0725	0.063	0.057	0.05	0.043	0.038	0.035	0.03	0.026
KMC3S010	0.145	0.133	0.115	0.10	0.085	0.075	0.07	0.06	0.055
KMC3S012	0.20	0.17	0.15	0.12	0.11	0.10	0.09	0.08	0.07
KMC3S016	0.21	0.20	0.18	0.16	0.14	0.13	0.12	0.11	0.09
KMC3S020	0.34	0.30	0.26	0.20	0.17	0.15	0.13	0.11	0.08
KMC3S025	0.37	0.33	0.29	0.25	0.22	0.20	0.17	0.15	0.12
KMC3S035	0.50	0.45	0.40	0.35	0.30	0.27	0.24	0.18	0.15
KMC3S050	0.71	0.64	0.57	0.50	0.42	0.39	0.35	0.31	0.25
KMC3S050-15	0.71	0.64	0.57	0.50	0.42	0.39	0.35	0.31	0.25
KMC3S075	1.14	1.01	0.88	0.75	0.65	0.59	0.54	0.49	0.41
KMC3S100	1.45	1.31	1.15	1.00	0.84	0.77	0.69	0.61	0.48
KMC3S110	1.64	1.46	1.30	1.06	0.92	0.83	0.80	0.65	0.52
KMC3S150	2.18	1.94	1.72	1.50	1.28	1.17	1.06	0.96	0.77
KMC3S200	2.92	2.64	2.35	2.00	1.79	1.64	1.50	1.22	1.14

■ KMC4S (1210) Series Ihold & Itrip Thermal Derating Curve



Derating Curve for KMC4S (1210) Series

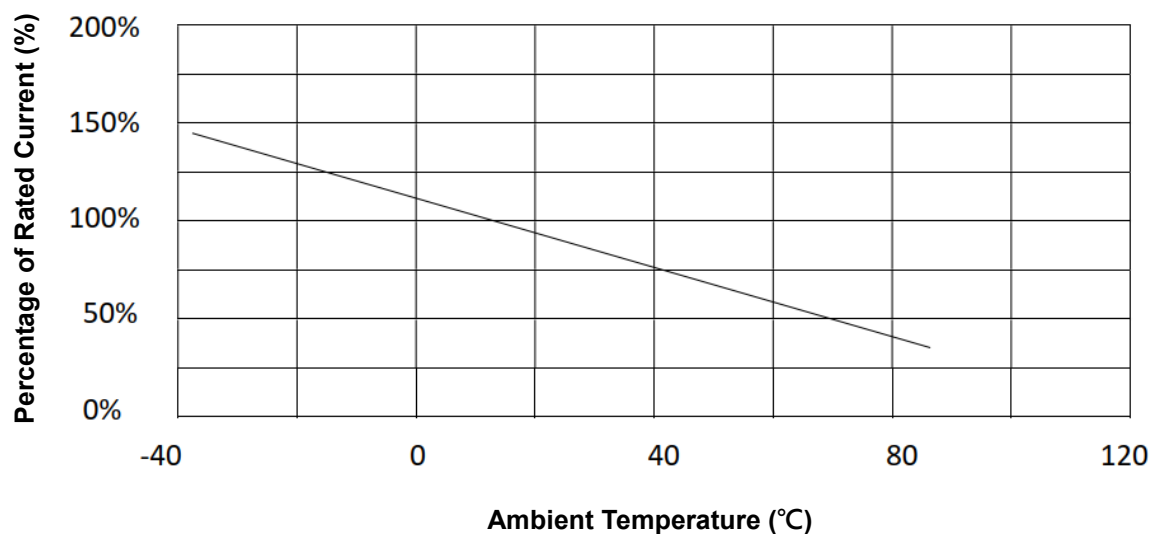

■ KMC4S (1210) Series Ihold Thermal Derating Chart

(Unit: A)

Part no	Ambient Temperature								
	-40°C	-20°C	0°C	23°C	40°C	50°C	60°C	70°C	85°C
KMC4S005	0.08	0.07	0.06	0.05	0.04	0.04	0.03	0.03	0.02
KMC4S010	0.16	0.14	0.12	0.10	0.08	0.07	0.06	0.05	0.03
KMC4S020	0.29	0.26	0.22	0.20	0.16	0.14	0.13	0.11	0.08
KMC4S035	0.47	0.45	0.40	0.35	0.33	0.28	0.24	0.21	0.18
KMC4S050	0.76	0.67	0.58	0.50	0.43	0.40	0.36	0.32	0.28
KMC4S075	1.00	0.97	0.86	0.75	0.64	0.59	0.54	0.48	0.40
KMC4S110	1.69	1.48	1.29	1.10	0.88	0.76	0.65	0.57	0.43
KMC4S150	2.13	1.92	1.71	1.50	1.26	1.14	1.01	0.89	0.71
KMC4S175	2.80	2.45	2.10	1.70	1.55	1.45	1.35	1.25	1.10

■ KMC5S (1812) Series Ihold & Itrip Thermal Derating Curve

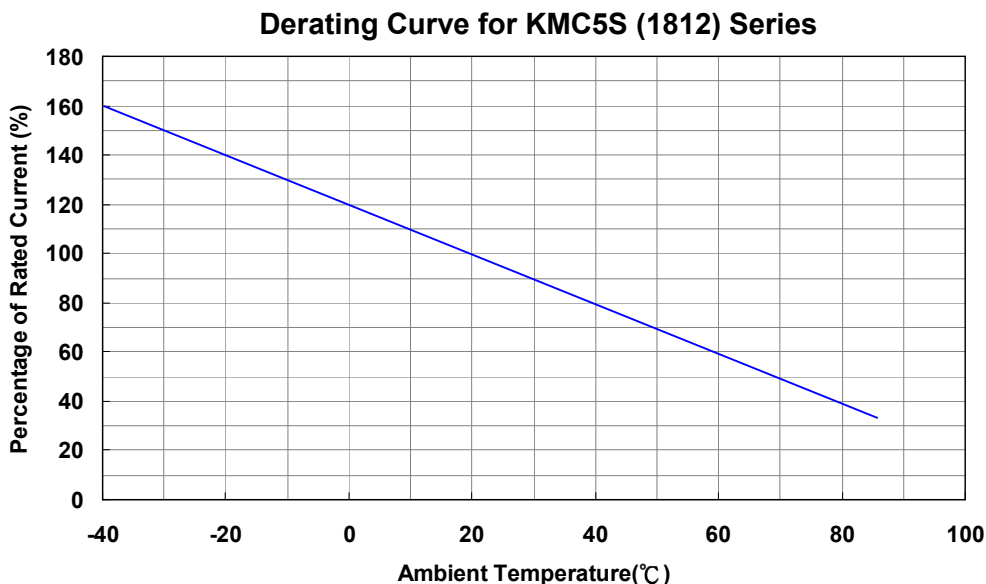

■ KMC5S (1812) Series Ihold Thermal Derating Chart

(Unit: A)

Part no	Ambient Temperature								
	-40°C	-20°C	0°C	23°C	40°C	50°C	60°C	70°C	85°C
KMC5S010	0.16	0.14	0.12	0.10	0.08	0.07	0.06	0.05	0.03
KMC5S014	0.23	0.19	0.17	0.14	0.12	0.10	0.09	0.08	0.06
KMC5S020	0.29	0.26	0.23	0.20	0.17	0.15	0.14	0.12	0.10
KMC5S035	0.50	0.45	0.40	0.35	0.29	0.26	0.24	0.21	0.19
KMC5S050	0.77	0.68	0.59	0.50	0.44	0.40	0.37	0.33	0.29
KMC5S075	1.15	1.01	0.88	0.75	0.65	0.60	0.55	0.49	0.43
KMC5S075-24	1.06	0.95	0.84	0.75	0.60	0.55	0.50	0.45	0.37
KMC5S075-33	1.10	1.00	0.88	0.75	0.66	0.60	0.55	0.47	0.36
KMC5S110	1.59	1.43	1.26	1.10	0.95	0.87	0.80	0.71	0.60
KMC5S110-16	1.58	1.43	1.27	1.10	0.95	0.85	0.77	0.71	0.58
KMC5S110-24	1.55	1.40	1.25	1.10	0.93	0.83	0.73	0.63	0.50
KMC5S110-33	1.55	1.40	1.25	1.10	0.93	0.83	0.73	0.63	0.50
KMC5S125	2.00	1.75	1.52	1.25	1.00	0.95	0.90	0.75	0.53
KMC5S125-16	2.00	1.75	1.52	1.25	1.00	0.95	0.90	0.75	0.53
KMC5S150	2.30	2.03	1.76	1.50	1.25	1.10	1.00	0.80	0.76
KMC5S150-12	2.04	1.88	1.68	1.50	1.25	1.10	1.00	0.80	0.60
KMC5S150-24	2.05	1.87	1.67	1.50	1.25	1.08	0.95	0.77	0.60
KMC5S160	2.27	2.05	1.83	1.60	1.35	1.25	1.15	1.00	0.85
KMC5S200	2.60	2.44	2.22	2.00	1.80	1.60	1.50	1.07	0.80
KMC5S200-16	2.60	2.44	2.22	2.00	1.80	1.60	1.50	1.07	0.80
KMC5S260	3.40	3.16	2.80	2.60	2.34	2.08	1.95	1.39	1.04
KMC5S260-16	3.40	3.16	2.80	2.60	2.34	2.08	1.95	1.39	1.04
KMC5S300	4.15	3.76	3.46	3.00	2.55	2.28	2.01	1.61	1.33

Polymer PTC Resettable Fuse: KMC Series SMD Type



■ KMC6S (2018) Series Ihold & Itrip Thermal Derating Curve

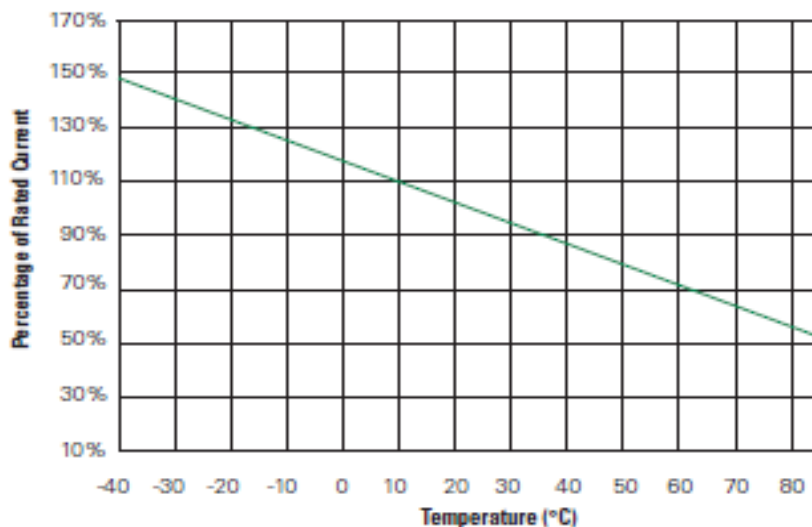

■ KMC6S (2018) Series Ihold Thermal Derating Chart

(Unit: A)

Part no	Ambient Operating Temperature							
	-40°C	-20°C	0°C	+23°C	+40°C	+60°C	+70°C	+85°C
KMC6S030	0.45	0.40	0.36	0.30	0.25	0.20	0.19	0.14
KMC6S050	0.92	0.80	0.65	0.55	0.44	0.33	0.30	0.24
KMC6S075	1.05	0.95	0.86	0.75	0.60	0.45	0.40	0.30
KMC6S100	1.66	1.47	1.29	1.10	0.91	0.73	0.63	0.50
KMC6S100-33	1.66	1.47	1.29	1.10	0.91	0.73	0.63	0.50
KMC6S150	2.25	2.00	1.76	1.50	1.25	1.00	0.86	0.68
KMC6S150-33	2.25	2.00	1.76	1.50	1.25	1.00	0.86	0.68
KMC6S200	2.80	2.50	2.18	2.00	1.84	1.50	1.34	1.15
KMC6S260-24	3.82	3.46	3.07	2.60	2.24	1.82	1.60	1.29
KMC6S300	4.40	3.96	3.52	3.00	2.65	2.20	1.96	1.59
KMC6S500	7.29	6.56	5.86	5.00	4.38	3.67	3.26	2.65

Polymer PTC Resettable Fuse: KMC Series

SMD Type



Recommended Soldering Condition

● IR-Reflow Soldering Profile

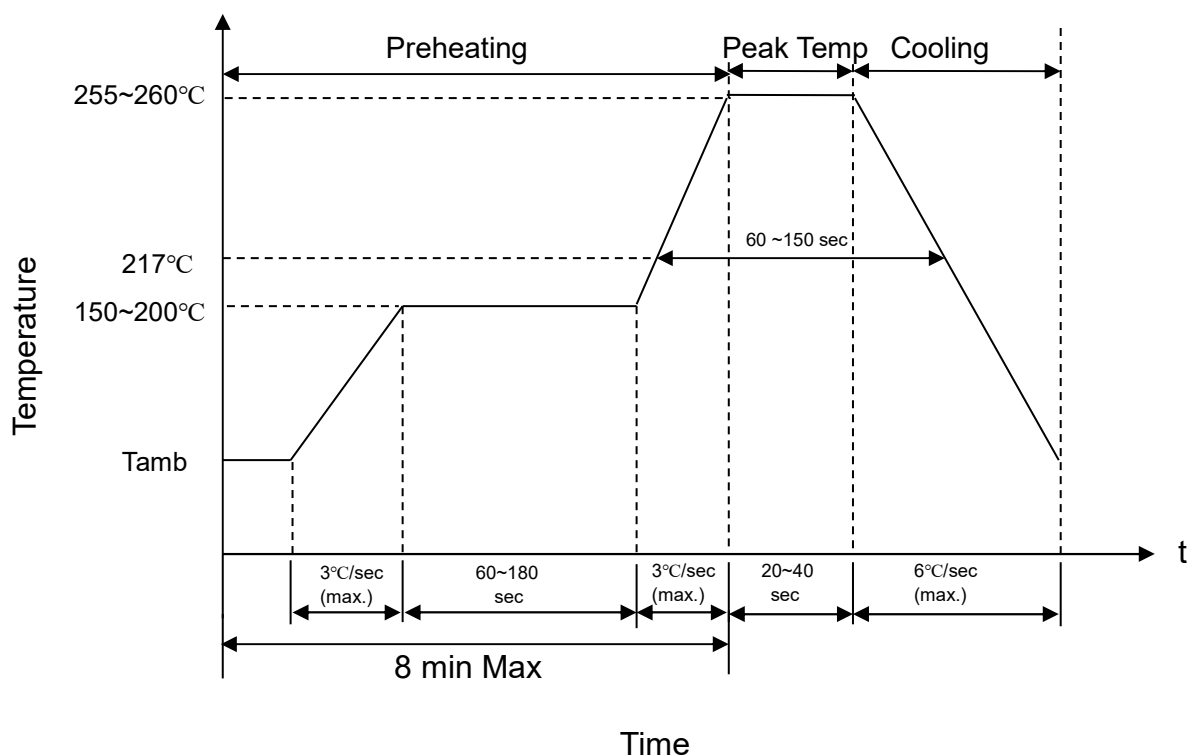

- Welding method of the product is reflow welding, and wave soldering is not recommended.
- Recommended reflow methods: IR, vapor phase, and hot air oven.
- Devices can be cleaned by using standard industry methods and solvents.

Note:

- If reflow temperature exceeds the recommended profile, devices may not meet the performance requirements.
- Devices are not designed to be wave soldered to the bottom side of the board.

■ Recommended Soldering Pad Dimensions (Nominal)

(Unit: mm)

Series	Size	A	B	C
KMC1S	0603	0.80	1.00	1.00
KMC2S	0805	1.20	1.00	1.50
KMC3S	1206	2.00	1.00	1.90
KMC4S	1210	2.00	1.00	2.80
KMC5S	1812	3.45	1.78	3.50
KMC6S	2018	3.40	1.50	4.60

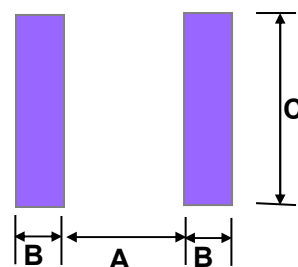

Polymer PTC Resettable Fuse: KMC Series

SMD Type



■ Reliability

Item	Standard	Test Condition / Methods	Criteria
Passive Aging	IEC 60738-1	85±5°C, 1000±24hrs	±10% typical resistance change
Humidity Aging	Specification Standard	85±5°C, 80~85%RH, 100±5hrs	±5% typical resistance change
Rapid Change of Temperature	IEC 60738-1	85±5/-40±5°C, 20 cycles, Duration:30min	-33% typical resistance change
Overload Endurance	UL 1434	Vmax,120% Imax, 50 cycles Vmax,300% Itrip, 6000 cycles	No visible damage
Trip Endurance	UL 1434	Vmax, Itrip ≤ I ≤ Imax, 1000±24hrs	No visible damage
Solderability	IEC 60068-2-58	245 ± 5 °C, 3 ± 0.3 sec	At least 95% of terminal electrode is covered by new solder.

■ Package

● Taping Specification

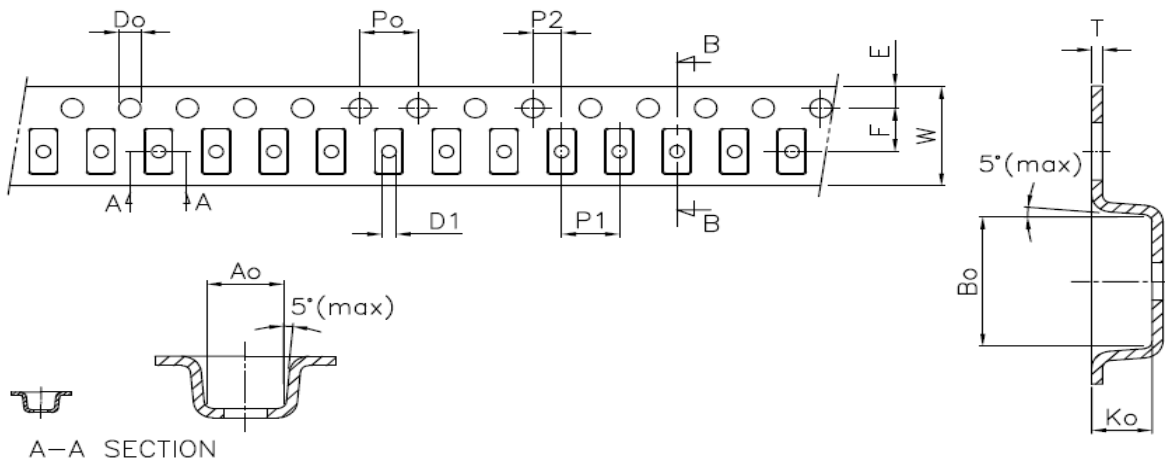

◆ KMC1S Series: SMD 0603 Type

For KMC1S010, KMC1S020, KMC1S025

(Unit: mm)

Index Size	A ₀	B ₀	K ₀	P ₀	P ₁	P ₂	T	E	F	D ₀	D ₁	W	10P ₀
	±0.05	±0.05	±0.05	±0.10	±0.10	±0.05	±0.05	±0.10	±0.05	+0.10/-0	+0.10 -0.05	+0.30 -0.10	±0.20
0603	1.10	1.85	0.60	4.00	4.00	2.00	0.20	1.75	3.50	1.50	0.50	8.00	40.00

Polymer PTC Resettable Fuse: KMC Series

SMD Type



For KMC1S035

(Unit: mm)

Index Size	A ₀	B ₀	K ₀	P ₀	P ₁	P ₂	T	E	F	D ₀	D ₁	W	10P ₀
	±0.10	±0.15	±0.05	±0.10	±0.10	±0.05	+0.05 -0.08	±0.10	±0.05	±0.05	Min.	±0.20	±0.20
0603	1.10	1.85	0.75	4.00	4.00	2.00	0.23	1.75	3.50	1.55	0.40	8.00	40.00

◆ KMC2S Series: SMD 0805 Type

(Unit: mm)

Index Size	A ₀	B ₀	K ₀	P ₀	P ₁	P ₂	T	E	F	D ₀	D ₁	W	10P ₀
	±0.10	±0.10	±0.05	±0.08	±0.10	±0.05	±0.10	±0.10	±0.05	±0.05	Min.	±0.10	±0.20
0805	1.60	2.30	0.90	4.00	4.00	2.00	0.25	1.75	3.50	1.55	1.00	8.00	40.00

◆ KMC3S Series: SMD 1206 Type

For KMC3S005, KMC3S010, KMC3S012, KMC3S016, KMC3S020, KMC3S025, KMC3S035, KMC3S050,
KMC3S075, KMC3S100

(Unit: mm)

Index Size	A ₀	B ₀	K ₀	P ₀	P ₁	P ₂	T	E	F	D ₀	D ₁	W	10P ₀
	±0.10	±0.10	±0.05	±0.10	±0.10	±0.10	±0.05	±0.10	±0.10	±0.05	Min.	±0.30	±0.20
1206	1.85	3.45	0.85	4.00	4.00	2.00	0.23	1.75	3.50	1.55	1.00	8.00	40.00

For KMC3S050-15, KMC3S110-16, KMC3S150, KMC3S200

(Unit: mm)

Index Size	A ₀	B ₀	K ₀	P ₀	P ₁	P ₂	T	E	F	D ₀	D ₁	W	10P ₀
	+0.1/-0	+0.1/-0	±0.05	±0.10	±0.10	±0.10	±0.05	±0.10	±0.10	±0.05	Min.	±0.30	±0.20
1206	1.95	3.55	1.40	4.00	4.00	2.00	0.23	1.75	3.50	1.55	1.00	8.00	40.00

◆ KMC4S Series: SMD 1210 Type

For KMC4S005, KMC4S010, KMC4S020, KMC4S035, KMC4S050, KMC4S075, KMC4S110,
KMC4S150, and KMC4S175

(Unit: mm)

Index Size	A ₀	B ₀	K ₀	P ₀	P ₁	P ₂	T	E	F	D ₀	D ₁	W	10P ₀
	±0.10	±0.10	±0.05	±0.10	±0.10	±0.10	±0.05	±0.10	±0.10	±0.05	Min.	±0.30	±0.20
1210	2.82	3.63	1.47	4.00	4.00	2.00	0.23	1.75	3.50	1.55	1.0(MIN)	8.00	40.00

Polymer PTC Resettable Fuse: KMC Series

SMD Type



◆ KMC5S Series: SMD 1812 Type

For KMC5S010, KMC5S014, KMC5S020, KMC5S035, KMC5S050, KMC5S075, KMC5S110, KMC5S110-24, KMC5S125, KMC5S150, KMC5S160, KMC5S200

(Unit: mm)

Index Size	A ₀	B ₀	K ₀	P ₀	P ₁	P ₂	T	E	F	D ₀	D ₁	W	10P ₀
	±0.10	±0.10	±0.05	±0.10	±0.10	±0.10	±0.03	±0.10	±0.10	±0.05	Min.	±0.30	±0.20
1812	3.50	5.00	0.90	4.00	8.00	2.00	0.25	1.75	5.50	1.55	1.50	12.00	40.00

For KMC5S050-60, KMC5S075-24, KMC5S075-33, KMC5S110-16, KMC5S110-33, KMC5S125-16, KMC5S150-12, KMC5S150-24, KMC5S200-16, KMC5S260, KMC5S260-16, KMC5S300

(Unit: mm)

Index Size	A ₀	B ₀	K ₀	P ₀	P ₁	P ₂	T	E	F	D ₀	D ₁	W	10P ₀
	±0.10	±0.10	±0.05	±0.10	±0.10	±0.10	±0.05	±0.10	±0.10	±0.05	Min.	±0.30	±0.20
1812	3.56	4.94	1.70	4.00	8.00	2.00	0.25	1.75	5.50	1.55	1.50	12.00	40.00

(Unit: mm)

◆ KMC6S Series: SMD 2018 Type

For KMC6S030, KMC6S100, KMC6S200

(Unit: mm)

Index Size	A ₀	B ₀	K ₀	P ₀	P ₁	P ₂	T	E	F	D ₀	D ₁	W	10P ₀
	±0.10	±0.10	±0.05	±0.10	±0.10	±0.10	±0.05	±0.10	±0.10	±0.05	Min.	±0.30	±0.20
2018	4.60	5.60	0.75	4.00	8.00	2.00	0.25	1.75	5.55	1.55	1.50	12.00	40.00

For KMC6S050, KMC6S075, KMC6S100-33, KMC6S150, KMC6S150-33, KMC6S260-24, KMC6S300, KMC6S500

(Unit: mm)

Index Size	A ₀	B ₀	K ₀	P ₀	P ₁	P ₂	T	E	F	D ₀	D ₁	W	10P ₀
	±0.10	±0.10	±0.05	±0.10	±0.10	±0.10	±0.05	±0.10	±0.10	±0.05	Min.	±0.30	±0.20
2018	4.60	5.60	1.36	4.00	8.00	2.00	0.25	1.75	5.50	1.55	1.50	12.00	40.00

Polymer PTC Resettable Fuse: KMC Series

SMD Type



Quantity

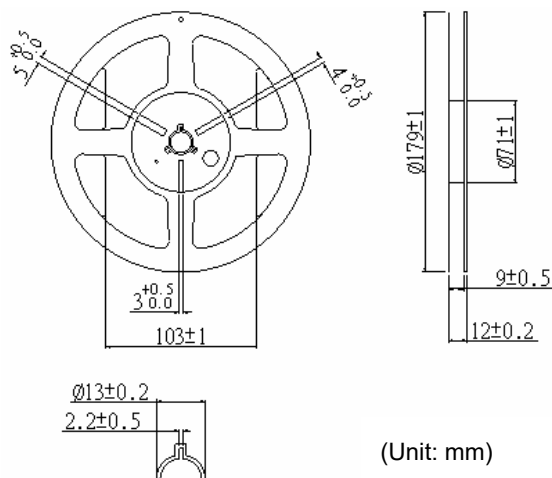

Size	Part no	Quantity (pcs/reel)
0603	KMC1S010, KMC1S020, KMC1S025	6,000
	KMC1S035	5,000
0805	For all parts	4,000
1206	KMC3S050-15, KMC3S110-16, KMC3S150, KMC3S200	2,500
	KMC3S005, KMC3S010, KMC3S012, KMC3S016, KMC3S020, KMC3S025, KMC3S035, KMC3S050, KMC3S075, KMC3S100, KMC3S110	5,000
1210	For all parts	3,000

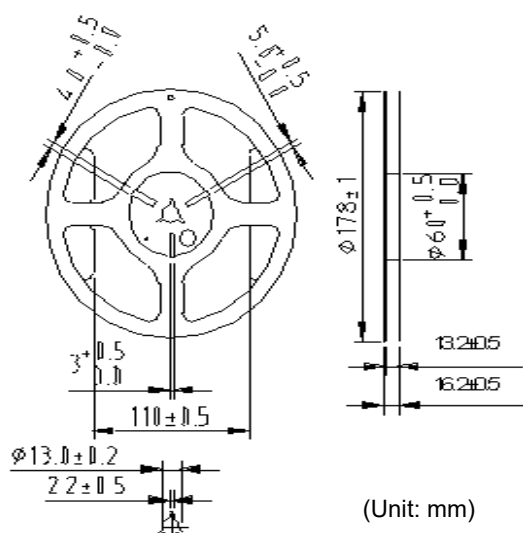

Size	Part no	Quantity (pcs/reel)
1812	KMC5S050-60, KMC5S075-24, KMC5S075-33, KMC5S110-16, KMC5S110-33, KMC5S125-16, KMC5S150-12, KMC5S150-24, KMC5S200-16, KMC5S260, KMC5S260-16, KMC5S300	1,000
	KMC5S010, KMC5S014, KMC5S020, KMC5S035, KMC5S050, KMC5S075, KMC5S110, KMC5S110-24, KMC5S125, KMC5S150, KMC5S160, KMC5S200	2,000
2018	KMC6S100, KMC6S200	2,000
	KMC6S030, KMC6S100-33, KMC6S150	1,500
	KMC6S050, KMC6S075, KMC6S150-33, KMC6S260-24, KMC6S300, KMC6S500	1,000

Warehouse Storage Conditions of Products

- Storage Conditions:
 - Storage Temperature: -10 °C~+ 40 °C
 - Relative humidity: ≤ 75%RH
 - Thermistors must be kept away from sunlight and stored in a non-corrosive atmosphere.
- Period of Storage: 1 year